

IEEE Std C57.12.70-2000

(Revision of
IEEE Std C57.12.70-1978)

IEEE Standard Terminal Markings and Connections for Distribution and Power Transformers

Transformers Committee
of the
IEEE Power Engineering Society

Approved 7 December 2000

IEEE-SA Standards Board

Abstract: Standard terminal markings and connections are described for single-phase and three-phase distribution, power, and regulating transformers. For terminal markings, it covers sequence designation, external terminal designation, neutral terminal designation, grounded terminal designation, and marking of full and tap winding terminals. Additive and subtractive polarity and parallel transformer operation are described. Connections of single-phase transformers in various configurations and angular displacement of three-phase transformers to connect to various system phase displacements are covered.

Keywords: transformer connections, transformer terminals, transformer polarity

The Institute of Electrical and Electronics Engineers, Inc.
3 Park Avenue, New York, NY 10016-5997, USA

Copyright © 2001 by the Institute of Electrical and Electronics Engineers, Inc.
All rights reserved. Published 16 March 2001. Printed in the United States of America.

Print: ISBN 0-7381-2732-9 SH94906
PDF: ISBN 0-7381-2733-7 SS94906

No part of this publication may be reproduced in any form, in an electronic retrieval system or otherwise, without the prior written permission of the publisher.

IEEE Standards documents are developed within the IEEE Societies and the Standards Coordinating Committees of the IEEE Standards Association (IEEE-SA) Standards Board. Members of the committees serve voluntarily and without compensation. They are not necessarily members of the Institute. The standards developed within IEEE represent a consensus of the broad expertise on the subject within the Institute as well as those activities outside of IEEE that have expressed an interest in participating in the development of the standard.

Use of an IEEE Standard is wholly voluntary. The existence of an IEEE Standard does not imply that there are no other ways to produce, test, measure, purchase, market, or provide other goods and services related to the scope of the IEEE Standard. Furthermore, the viewpoint expressed at the time a standard is approved and issued is subject to change brought about through developments in the state of the art and comments received from users of the standard. Every IEEE Standard is subjected to review at least every five years for revision or reaffirmation. When a document is more than five years old and has not been reaffirmed, it is reasonable to conclude that its contents, although still of some value, do not wholly reflect the present state of the art. Users are cautioned to check to determine that they have the latest edition of any IEEE Standard.

Comments for revision of IEEE Standards are welcome from any interested party, regardless of membership affiliation with IEEE. Suggestions for changes in documents should be in the form of a proposed change of text, together with appropriate supporting comments.

Interpretations: Occasionally questions may arise regarding the meaning of portions of standards as they relate to specific applications. When the need for interpretations is brought to the attention of IEEE, the Institute will initiate action to prepare appropriate responses. Since IEEE Standards represent a consensus of all concerned interests, it is important to ensure that any interpretation has also received the concurrence of a balance of interests. For this reason, IEEE and the members of its societies and Standards Coordinating Committees are not able to provide an instant response to interpretation requests except in those cases where the matter has previously received formal consideration.

Comments on standards and requests for interpretations should be addressed to:

Secretary, IEEE-SA Standards Board
445 Hoes Lane
P.O. Box 1331
Piscataway, NJ 08855-1331
USA

Note: Attention is called to the possibility that implementation of this standard may require use of subject matter covered by patent rights. By publication of this standard, no position is taken with respect to the existence or validity of any patent rights in connection therewith. The IEEE shall not be responsible for identifying patents for which a license may be required by an IEEE standard or for conducting inquiries into the legal validity or scope of those patents that are brought to its attention.

IEEE is the sole entity that may authorize the use of certification marks, trademarks, or other designations to indicate compliance with the materials set forth herein.

Authorization to photocopy portions of any individual standard for internal or personal use is granted by the Institute of Electrical and Electronics Engineers, Inc., provided that the appropriate fee is paid to Copyright Clearance Center. To arrange for payment of licensing fee, please contact Copyright Clearance Center, Customer Service, 222 Rosewood Drive, Danvers, MA 01923 USA; (978) 750-8400. Permission to photocopy portions of any individual standard for educational classroom use can also be obtained through the Copyright Clearance Center.

Introduction

(This introduction is not a part of IEEE Std C57.12.70-2000, IEEE Standard Terminal Markings and Connections for Distribution and Power Transformers.)

The Terminology, Units, and Terminal Markings Working Group of the IEEE Transformers Committee was formed in January 1995. One of its two projects was to review and update this standard, which was last issued by ANSI in 1978.

The purpose of IEEE Std C57.12.70-1998 is to specify standard terminal markings and connections for distribution and power transformers.

The content of this revision of IEEE Std C57.12.70-1998, compared to the 1978 version, is very similar. The major effort of the Working Group was to reorganize the standard to comply with the approved style of currently published IEEE standards, to update reference standards, and to add terminal marking requirements for padmounted compartmental transformers.

At the time the revision of this standard was completed, the Working Group on Terminology, Units and Terminal Markings had the following membership:

Thomas P. Traub, *Chair*

Wallace B. Binder
Robert L. Grubb

John W. Matthews
B. K. Patel

Thomas A. Prevost
F. N. Young

The following persons were on the balloting committee:

Dennis J. Allan	Lars-Erik Juhlin	Pierre Riffon
George Allen	Brian Klaponski	Peter G. Risse
Raymond Allustiarti	Egon Koenig	Arlise L. Robinson, Jr.
Glenn Andersen	Barin Kumar	John R. Rossetti
Stephen Antosz	John G. Lackey	Mahesh P. Sampat
Jim Antweiler	Tim D. Lewis	Vallamkonda Sankar
Jim C. Arnold	Harold F. Light	Leo J. Savio
Roy A. Bancroft	Larry A. Lowdermilk	Rick Sawyer
Ron L. Barker	Donald L. Lowe	Wes W. Schwartz
Edward A. Bertolini	Joe D. MacDonald	Pat Scully
Wallace B. Binder	William A. Maguire	Dilipkumar Shah
William E. Boettger	John W. Matthews	Devki Sharma
Joe V. Bonucchi	Jack W. McGill	Vic Shenoy
John D. Borst	Charles Patrick McShane	Hyeong Jin Sim
Don Chu	R. E. Minkwitz, Sr.	Tarkeshwar Singh
Jerry L. Corkran	Harold R. Moore	Leonard R. Smith
Dan W. Crofts	W. E. Morehart	Stephen D. Smith
John A. Ebert	Daniel H. Mulkey	J. Ed Smith
Fred E. Elliott	Charles R. Murray	James E. Smith
Joe Foldi	R. J. Musil	Jerry W. Smith
Ron Fox	William H. Mutschler, Jr.	Steven L. Snyder
Dudley L. Galloway	Carl G. Niemann	Ronald J. Stahara
Harry D. Gianakouros	Larry Nunnery	L.R. Stensland
Ramsis S. Girgis	Paul E. Orehek	John C. Sullivan
Richard D. Graham	Dennis Orten	James A. Thompson
Robert L. Grubb	Dhiru S. Patel	Thomas P. Traub
Robert L. Grunert	B. K. Patel	Al Traut
Michael E. Haas	Wesley F. Patterson	Subhash C. Tuli
Geoff H. Hall	Dave Payne	Georges H. Vaillancourt
N Wayne Hansen	Paulette A. Payne	Robert A. Veitch
James H. Harlow	Thomas J. Pekarek	Loren B. Wagenaar
William R. Henning	Dan D. Perco	Ralph D. Wakeam
Philip J. Hopkinson	Mark D. Perkins	Barry H. Ward
James D. Huddleston, III	Linden W. Pierce	Robert Whearty
John O. Hunt	R Leon Plaster	A. L. Wilks
Virendra Jhonsa	Donald W. Platts	William G. Wimmer
Anthony J. Jonnatti	Jeewan L. Puri	W. E. Wrenn
		F. N. Young

When the IEEE-SA Standards Board approved this standard on 7 December 2000, it had the following membership:

Donald N. Heirman, *Chair*

James T. Carlo, *Vice Chair*

Judith Gorman, *Secretary*

Satish K. Aggarwal	James H. Gurney	James W. Moore
Mark D. Bowman	Richard J. Holleman	Robert F. Munzner
Gary R. Engmann	Lowell G. Johnson	Ronald C. Petersen
Harold E. Epstein	Robert J. Kennelly	Gerald H. Peterson
H. Landis Floyd	Joseph L. Koepfinger*	John B. Posey
Jay Forster*	Peter H. Lips	Gary S. Robinson
Howard M. Frazier	L. Bruce McClung	Akio Tojo
Ruben D. Garzon	Daleep C. Mohla	Donald W. Zipse

*Member Emeritus

Also included is the following nonvoting IEEE-SA Standards Board liaison:

Alan Cookson, *NIST Representative*

Donald R. Volzka, *TAB Representative*

Noelle D. Humenick

IEEE Standards Project Editor

Contents

1.	Overview	1
1.1	Scope	1
1.2	References	1
2.	Marking of terminals and identification of windings	3
2.1	General	3
2.2	Sequence designation	3
2.3	External terminal designation	3
2.4	Neutral terminal designation	3
2.5	Grounded terminal designation	3
3.	Single-phase transformers	3
3.1	Types of transformers	4
3.2	Subtractive and additive polarity	5
3.3	Order of numbering terminals of any winding	11
3.4	Order of numbering terminals of different windings	11
3.5	Location of H1 terminal	12
3.6	Parallel operation	12
4.	Angular displacement and connections for single-phase transformers in three-phase and six-phase banks	13
5.	Phase relationships and terminal markings for three-phase transformers	17
5.1	Relation between highest voltage winding and other windings	17
5.2	Phase relationships and terminal markings	19
5.3	Marking of full winding terminals	19
5.4	Tap leads	20
5.5	Location of external terminals	21
5.6	Interphase connections made outside of case	23
5.7	Parallel operation	23
6.	Terminal markings for three-phase to six-phase transformers	23
6.1	General	23
6.2	Marking of full winding terminals	23
6.3	Relation between three-phase and six-phase windings	24
6.4	Tap leads	24
7.	Use of transformers with standard voltage diagrams in connecting systems of various phase displacements	25
7.1	General	25
7.2	0° phase displacement: Δ - Δ or Y-Y	26
7.3	30° lagging phase displacement: Δ -Y or Y- Δ	26
7.4	30° leading phase displacement: Δ -Y or Y- Δ	26
7.5	Summary of preceding examples	27

IEEE Standard Terminal Markings and Connections for Distribution and Power Transformers

1. Overview

1.1 Scope

This standard describes the terminal markings and connections for distribution, power, and regulating transformers covered in the C57 series of IEEE and ANSI standards, guides, and recommended practices.

1.2 References

When the following standards are superseded by a revision, the revision shall apply:

ANSI C57.12.10-1988, American National Standard for Transformers—230 kV and Below 833/958 through 8333/10 417 kVA, Single-Phase, and 750/862 through 60 000/80 000/100 000 kVA, Three-Phase without Load Tap Changing; and 3750/4687 through 60 000/80 000/100 000 kVA with Load Tap Changing—Safety Requirements.¹

ANSI C57.12.20-1997, American National Standard for Overhead Distribution Transformers, 500 kVA and Smaller: High Voltage, 34 500 Volts and below: Low Voltage, 7970/13 800 Y Volts and below—Requirements.

ANSI C57.12.22-1989, American National Standard for Transformers—Pad-Mounted, Compartmental-Type, Self-Cooled, Three-Phase Distribution Transformers with High-Voltage Bushings, 2500 kVA and Smaller: High-Voltage, 34 500 GrdY/19 920 Volts and Below; Low Voltage, 480 Volts and Below—Requirements.

ANSI C57.12.24-1992, American National Standard for Transformers--Underground-Type Three-Phase Distribution Transformers, 2500 kVA and Smaller; High Voltage, 34 500 GrdY/19 920 Volts and Below; Low Voltage, 480 Volts and Below—Requirements.²

¹ANSI publications are available from the Sales Department, American National Standards Institute, 11 West 42nd Street, 13th Floor, New York, NY 10036, USA (<http://www.ansi.org/>).

²ANSI C57.12.24-1992 has been withdrawn; however, copies can be obtained from the Sales Department, American National Standards Institute, 11 West 42nd Street, 13th Floor, New York, NY 10036, USA (<http://www.ansi.org/>).

ANSI C57.12.25-1990, American National Standard for Transformers—Pad-Mounted, Compartmental-Type, Self-Cooled, Single-Phase Distribution Transformers with Separable Insulated High-Voltage Connectors; High Voltage, 34 500 GrdY/19 920 Volts and Below; Low Voltage, 240/120 Volts; 167 kVA and Smaller—Requirements.

ANSI C57.12.40-1994, American National Standard for Secondary Network Transformers—Subway and Vault Types (Liquid Immersed)—Requirements.

ANSI C57.12.50-1981 (Reaff 1989), American National Standard Requirements for Ventilated Dry-Type Distribution Transformers, 1 to 500 kVA, Single-Phase, and 15 to 500 kVA, Three-Phase, with High-Voltage 601 to 34 500 Volts, Low-Voltage 120 to 600 Volts.

ANSI C57.12.51-1981 (Reaff 1989), American National Standard Requirements for Ventilated Dry-Type Power Transformers, 501 kVA and Larger, Three-Phase, with High-Voltage 601 to 34 500 Volts, Low-Voltage 208Y/120 to 4160 Volts.

ANSI C57.12.52-1981 (Reaff 1989), American National Standard Requirements for Sealed Dry-Type Power Transformers, 501 kVA and Larger, Three-Phase, with High-Voltage 601 to 34 500 Volts, Low-Voltage 208Y/120 to 4160 Volts.

IEEE 100, *The Authoritative Dictionary of IEEE Standards Terms*, Seventh Edition.³

IEEE Std C57.12.00-2000, IEEE Standard General Requirements for Liquid-Immersed Distribution, Power, and Regulating Transformers.

IEEE Std C57.12.01-1998, IEEE Standard General Requirements for Dry-type Distribution and Power Transformers Including Those with Solid-Cast and/or Resin-Encapsulated Windings.

IEEE Std C57.12.23-1992 (Reaff 1999), IEEE Standard for Transformers—Underground-Type, Self-Cooled, Single-Phase Distribution Transformers With Separable, Insulated, High-Voltage Connectors; High Voltage (24 940 GrdY/14 400 V and Below) and Low Voltage (240/120 V, 167 kVA and Smaller).

IEEE Std C57.12.26-1992, IEEE Standard for Pad-Mounted, Compartmental-Type, Self-Cooled, Three-Phase Distribution Transformers for Use with Separable Insulated High-Voltage Connectors (34 500 GrdY/19 920 V and Below; 2500 kVA and Smaller)⁴.

IEEE Std C57.12.80-1978 (Reaff 1992), IEEE Standard Terminology for Power and Distribution Transformers.

IEEE Std C57.12.90-1999, IEEE Standard Test Code for Liquid-Immersed Distribution, Power, and Regulating Transformers and IEEE Guide for Short Circuit Testing of Distribution and Power Transformers.

IEEE Std C57.12.91-1995, IEEE Standard Test Code for Dry-Type Distribution and Power Transformers.

³IEEE publications are available from the Institute of Electrical and Electronics Engineers, 445 Hoes Lane, P.O. Box 1331, Piscataway, NJ 08855-1331, USA (<http://standards.ieee.org/>).

⁴IEEE Std C57.12.26-1992 has been withdrawn; however, copies can be obtained from Global Engineering, 15 Inverness Way East, Englewood, CO 80112-5704, USA, tel. (303) 792-2181 (<http://global.ihs.com/>).

2. Marking of terminals and identification of windings

2.1 General

The windings of a transformer shall be distinguished from one another as follows: two-winding transformers shall have their windings designated as high voltage (HV or H) and low voltage (LV or X). Transformers with more than two windings shall have their windings designated as H, X, Y, or Z.

2.2 Sequence designation

The highest voltage winding shall be designated as HV or H, except for transformers designed for three-phase to six-phase transformation (see Clause 6). The other windings, in order of decreasing voltage, are designated as X, Y, and Z. If two (or more) windings have the same voltage and different kVA (kilo-volt-ampere) ratings, the higher kVA winding receives the prior letter designation of the two (or more) letters available, according to the sequence by voltage as explained above. If two or more windings have the same kVA and voltage rating, the designations of these windings are arbitrarily assigned.

2.3 External terminal designation

In general, external terminals shall be distinguished from one another by marking each terminal with a capital letter, followed by a subscript number. The terminals of the H winding are marked H_1 , H_2 , H_3 , etc. The terminals of the X winding are marked X_1 , X_2 , X_3 , etc.

When two external terminals are connected to the same end of a winding, such as the terminals on loop feed transformers, they shall be identified by the same capital letter and subscripted numeral followed by an additional subscripted letter A or B, for example, H_{1A} and H_{1B} , H_{2A} and H_{2B} .

The identification of external terminals shall be accomplished either by the use of the sketches on the nameplate showing locations of specific terminals, or by physically marking terminals.

2.4 Neutral terminal designation

A neutral terminal of a three-phase transformer shall be marked with the proper letter followed by the subscript 0, for example, H_0 , X_0 , etc. A neutral terminal common to two or more windings of a single or three-phase transformer shall be marked with the combination of the proper winding letters, each followed by the subscript 0; for example, H_0X_0 , as in the case of autotransformers. A terminal brought out from the winding for some other use than that of a neutral terminal (e.g., a 50% starting tap) shall be marked as a tap terminal.

2.5 Grounded terminal designation

If a transformer has a two-terminal winding with one terminal grounded and the other ungrounded, the subscript 2 terminal shall be the grounded terminal.

3. Single-phase transformers

Polarity and terminal markings of single-phase transformers are described in 3.1 through 3.4.

3.1 Types of transformers

3.1.1 Distribution transformers, liquid-insulated

Polarity shall be subtractive for all liquid-insulated distribution transformers, except as otherwise described in applicable sections of IEEE Std C57.12.00-2000 and ANSI C57.12.20-1997, which specify additive polarity for single-phase transformers in sizes 200 kVA and smaller having high-voltage windings 8660 volts and below.

Terminal markings shall be as shown in this standard except as otherwise specified in IEEE Std C57.12.23-1992 and ANSI C57.12.25-1990.

3.1.2 Power transformers, liquid-insulated

Polarity shall be subtractive. Terminal markings not described in IEEE Std C57.12.00-2000 or in ANSI C57.12.10-1988 shall be in accordance with Clause 3 of this standard.

3.1.3 Dry-type transformers

Polarity shall be subtractive. Terminal markings not described in IEEE Std C57.12.01-1998 shall be in accordance with Clause 3 of this standard.

3.1.4 Autotransformers

Single-phase autotransformer terminals shall, as far as practicable, be marked in accordance with the requirements for subtractive polarity (see Figure 1).

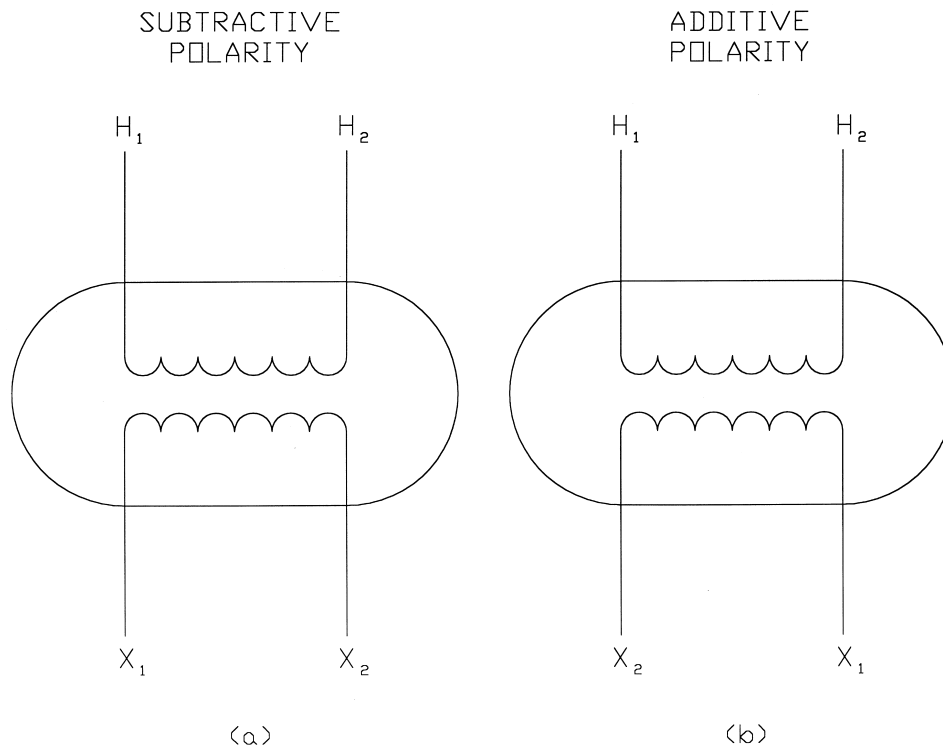
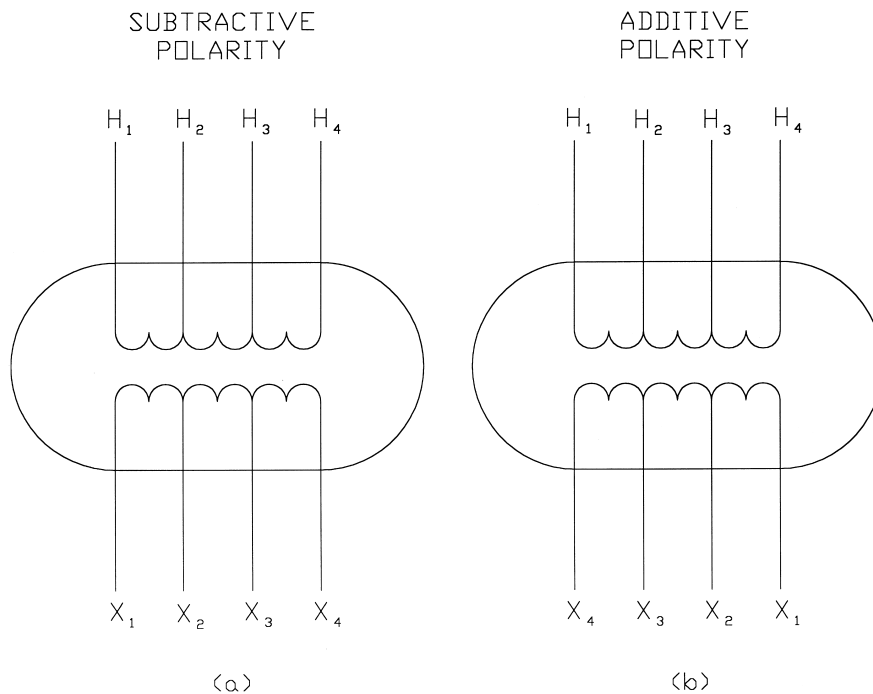

**Figure 1—Single-phase transformer terminal markings
(simple H and X windings without taps)**

3.2 Subtractive and additive polarity

When terminals of any winding are brought outside the tank and marked per 3.3, 3.4, or 3.5, the polarity of a transformer is

- Subtractive when H_1 and X_1 are adjacent. See Figure 1, Figure 2(a), Figure 3(a), Figure 4(a), Figure 5, Figure 6(a), Figure 7(a), Figure 8(a), Figure 9(a), Figure 10(a), Figure 11(a), Figure 12(a), and Figure 13(a).
- Additive when H_1 is diagonally located with respect to X_1 . See Figure 2(b), Figure 3(b), Figure 4(b), Figure 6(b), Figure 7(b), Figure 8(b), Figure 9(b), Figure 10(b), Figure 11(b), Figure 12(b), and Figure 13(b).
- The same rule applies between the H and Y winding and between the H and Z winding. For example, when Y_1 or Z_1 is on the left when facing the Y or Z side of the case, respectively, the polarity is subtractive; conversely, when Y_1 or Z_1 is on the right when facing the Y or Z side of the case, respectively, the polarity is additive.



**Figure 2—Single-phase transformer terminal markings
(simple H and X windings with taps)**

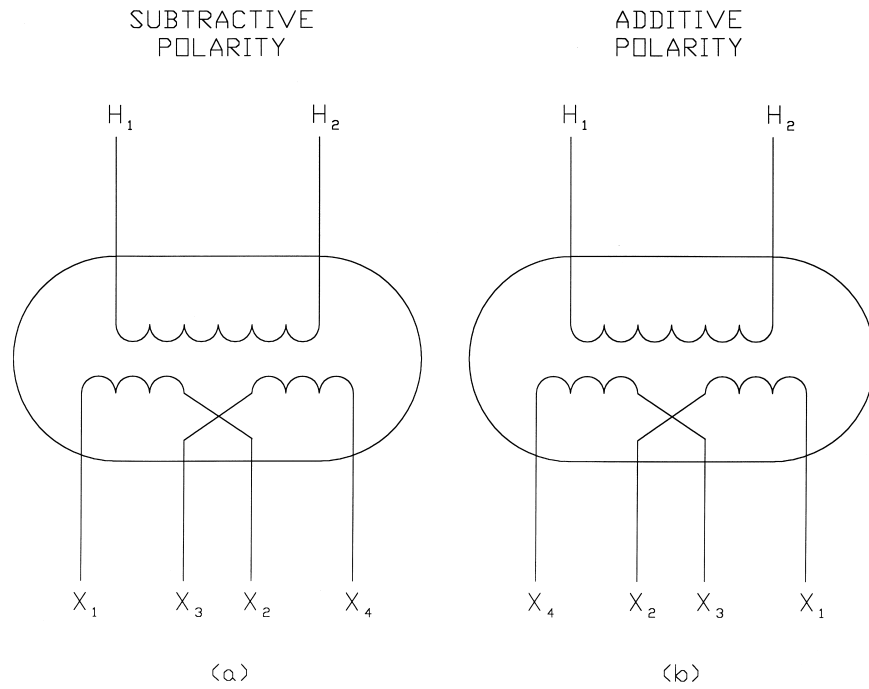

**Figure 3—Single-phase transformer terminal markings
(series multiple X winding without taps)**

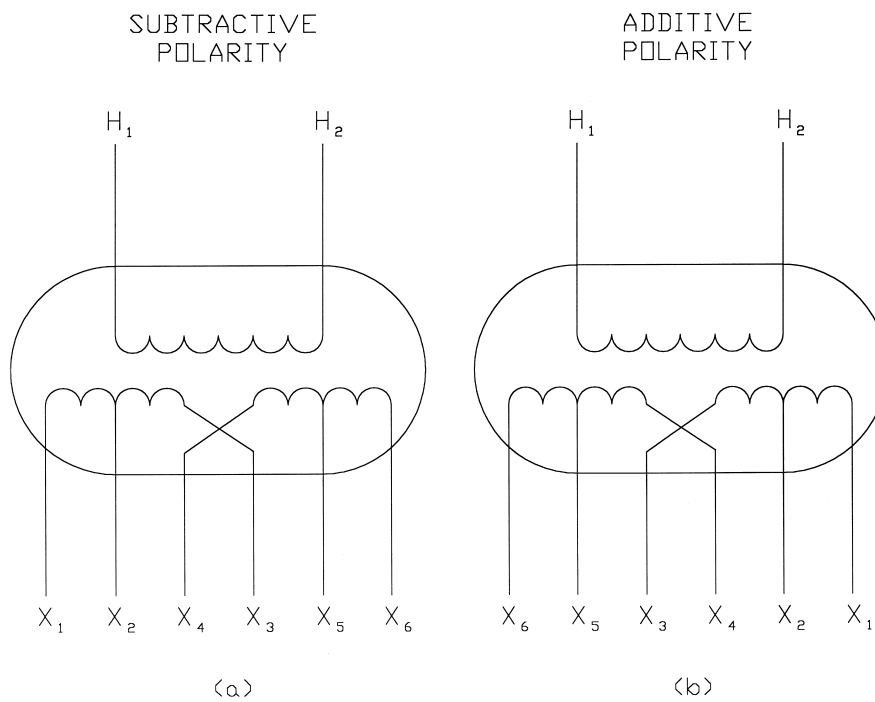

**Figure 4—Single-phase transformer terminal markings
(series multiple X winding with taps)**

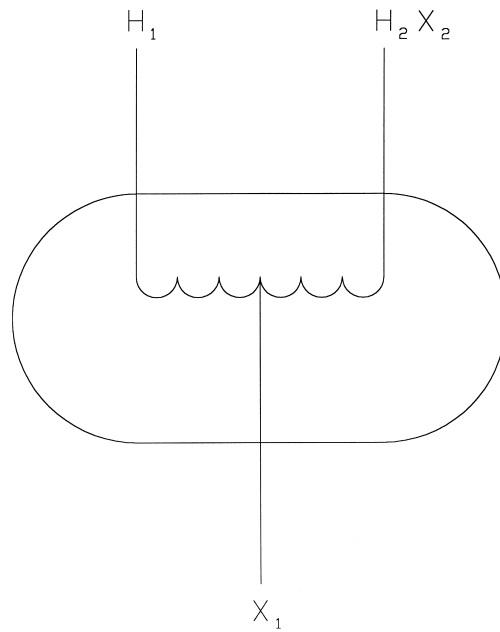
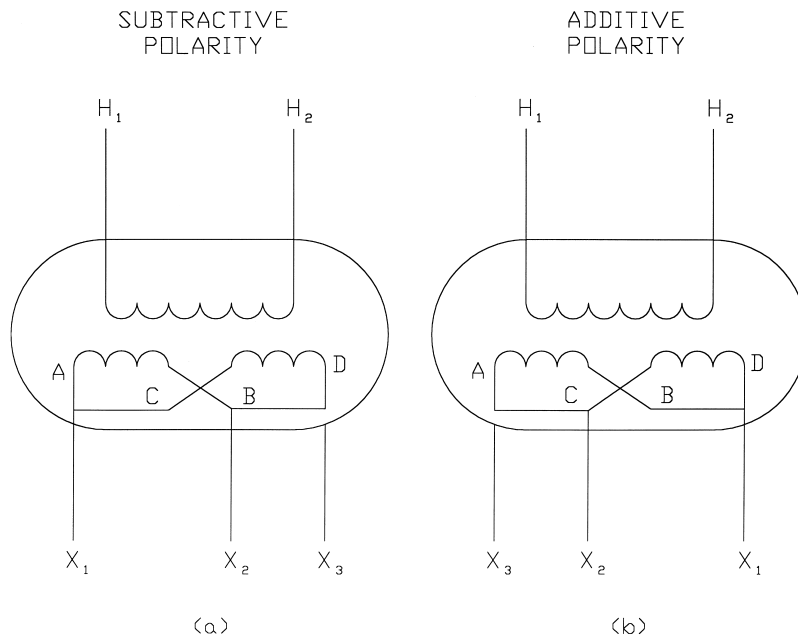

Figure 5—Single-phase transformer terminal markings (autotransformer)



Figure 6—Single-phase transformer terminal markings (three-wire series connection) (transformers having neutral brought out between outside terminals)



**Figure 7—Single-phase transformer terminal markings
(two-wire multiple connection)**

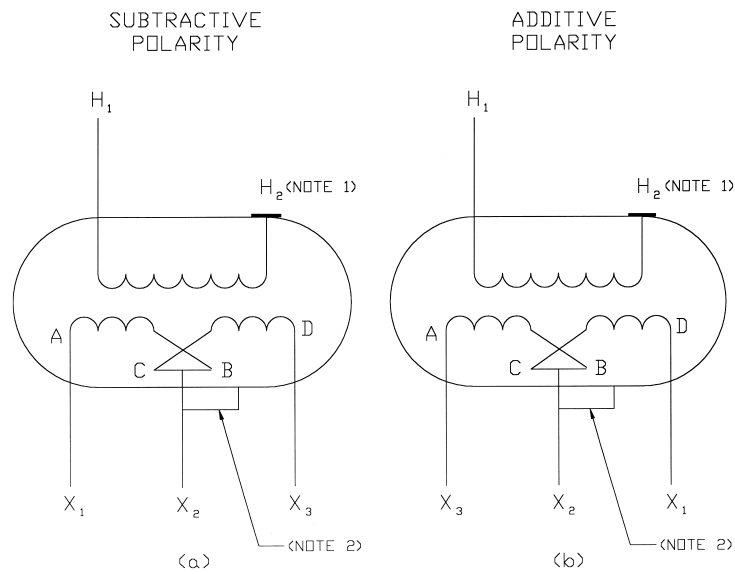

NOTES

- 1—Tank grounding connector.
- 2—Bolted to case externally.
(Connection to be furnished by user.)

**Figure 8—Single-phase transformer terminal markings
(three-wire series connection)
(transformers having neutral brought out between outside terminals)**

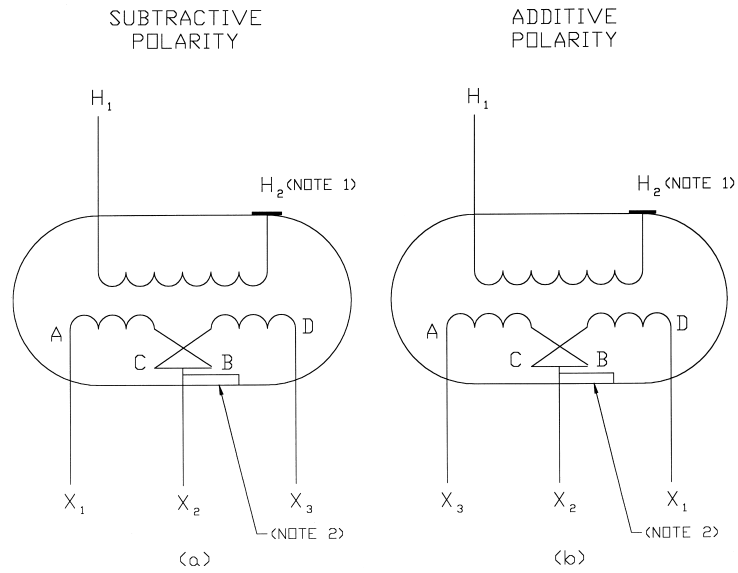

NOTES
1—Tank grounding connector.
2—Bolted to case internally.

**Figure 9—Single-phase transformer terminal markings
(three-wire series connection)
(transformers having neutral brought out between outside terminals)**

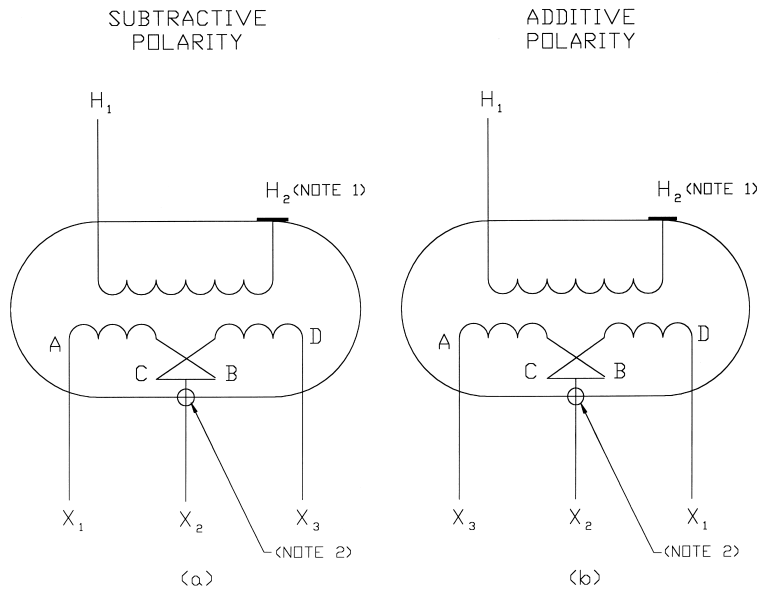

NOTES
1—Tank grounding connector.
2—Bolted to case internally.
3—Figure 10(a) and (b) are related to single-phase submersible transformers with secondary cable lead bushings, which require internal neutral grounding to the tank but externally appear to be an insulated neutral cable.

**Figure 10—Single-phase transformer terminal markings
(Three-wire series connection)
(transformers having neutral brought out between outside terminals)**

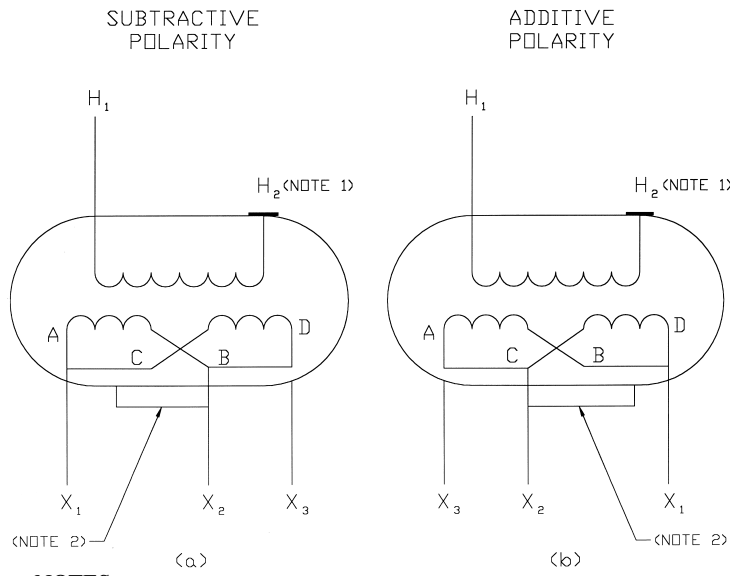

NOTES
 1—Tank grounding connector.
 2—Bolted to case externally.
 (Connection to be furnished by user.)

Figure 11—Single-phase transformer terminal markings (two-wire multiple connection)

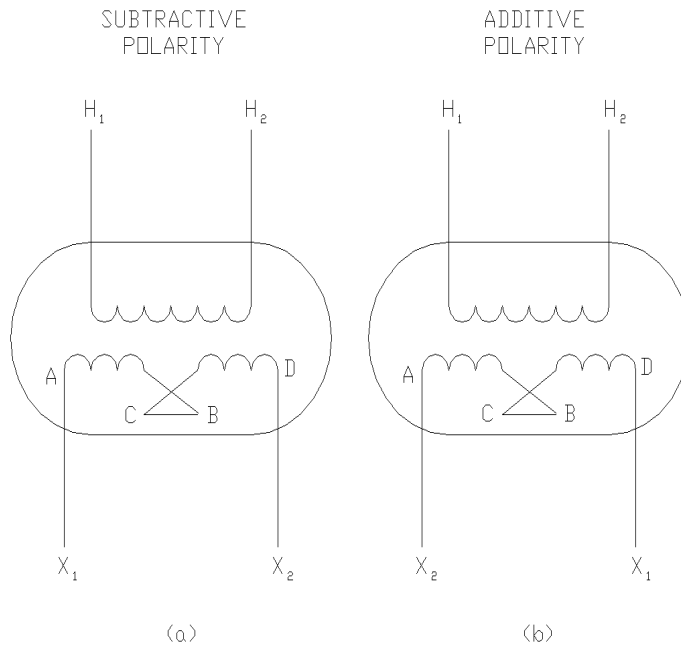
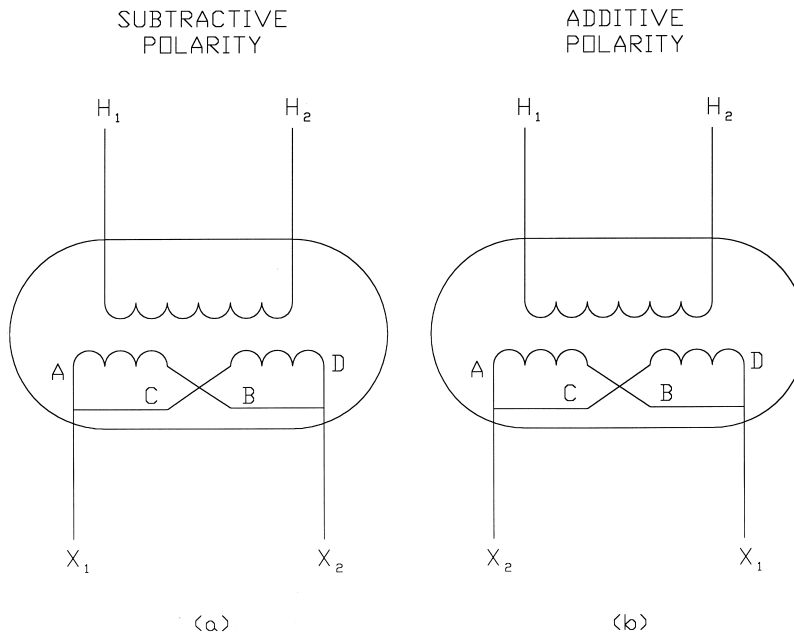

Figure 12—Single-phase transformer terminal markings (two-wire series connection)



**Figure 13—Single-phase transformer terminal markings
(two-wire multiple connection)**

3.3 Order of numbering terminals of any winding

3.3.1 Terminal numbers

The terminals of any winding whose leads are brought out of the case shall be numbered 1, 2, 3, 4, 5, etc., the lowest and highest numbers marking the full winding and the intermediate numbers marking fractions of windings or taps. All numbers shall be so applied that the voltage difference from any terminal having a lower number toward any terminal having a higher number shall have the same sign at any instant (see Figure 2 and Figure 3).

3.3.2 Series-multiple winding

If a winding is divided into two or more parts for series-multiple connections and the leads of these parts are brought out of the case, the above rule shall apply for the series connection with the addition that the terminations of each portion of the winding shall be given consecutive numbers (see Figure 2 through Figure 4 for four or six leads brought out and Figure 6 through Figure 11 for three leads brought out).

3.3.3 Two leads through one bushing

When two leads are brought out of the case through one bushing (to minimize inductive effect), such terminals shall be physically identified by stamping or tagging in compliance with 3.3.1.

3.4 Order of numbering terminals of different windings

The numbering of the terminals of the H winding and the terminals of the X winding shall be applied so that when H_1 and X_1 are connected together and voltage is applied to the transformer, the voltage between the highest numbered H terminal and the highest numbered X terminal is less than the voltage of the H winding.

When more than two windings are used, the same relationship shall apply between each pair of windings.

3.5 Location of H₁ terminal

The H₁ lead shall be brought out as the right-hand terminal of the high-voltage group as seen when facing the highest voltage side of the case; other H terminals shall be in numerical order from right to left, except as modified by specific product standards (e.g., IEEE Std C57.12.23-1992 and ANSI C57.12.25-1990).

When only one lead of the high-voltage winding is brought out (the other lead being connected to the tank internally), it shall be designated as H₁. For polarity marking and testing, this H₁ terminal shall be regarded as located on the right, when facing the high-voltage side of the case, regardless of its actual location.

When the high-voltage leads are brought out through two bushings of different insulation levels, the bushing having the higher voltage level shall be designated as H₁ and shall be located on the right-hand side when facing the high-voltage side of the case, except as modified by specific product standards (e.g., IEEE Std C57.12.23-1992 and ANSI C57.12.25-1990).

3.6 Parallel operation

Transformers having terminals marked in accordance with this standard may be operated in parallel by connecting similarly marked terminals together, provided their ratios, voltages, resistances, reactances, and ground connections are such as to permit parallel operation (see Figure 14 for connections for transformers in parallel).

NOTE—In some cases, designs may be such as to permit parallel operation, although, due to a difference in the number of tap terminals, the terminals to be connected together may not be similarly marked.

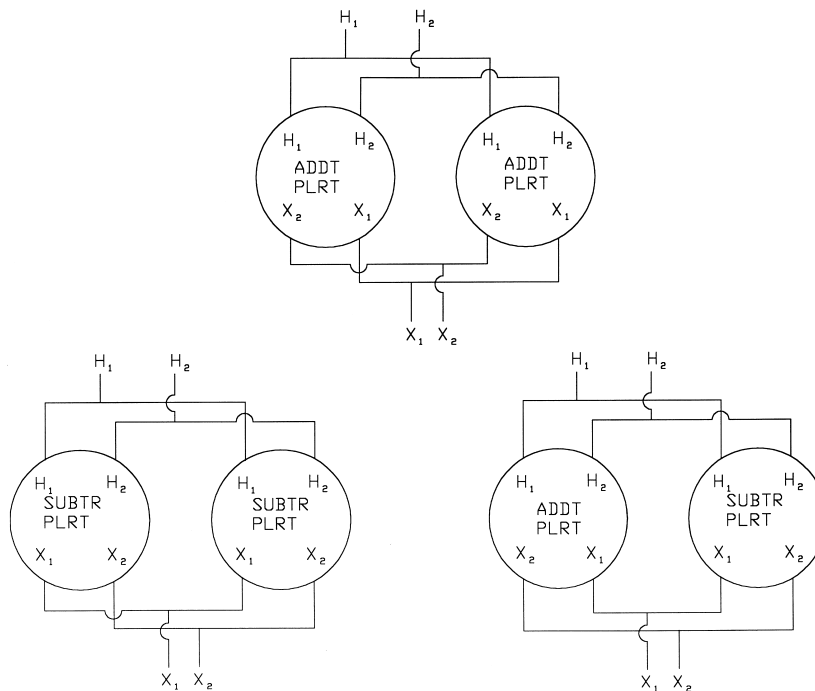

NOTE—This figure is included as information to illustrate the connection in parallel of single-phase transformers of additive polarity, additive and subtractive polarity, and subtractive polarity in banks.

Figure 14—Connections for single-phase transformers in parallel

4. Angular displacement and connections for single-phase transformers in three-phase and six-phase banks

See Figure 15 through Figure 18.

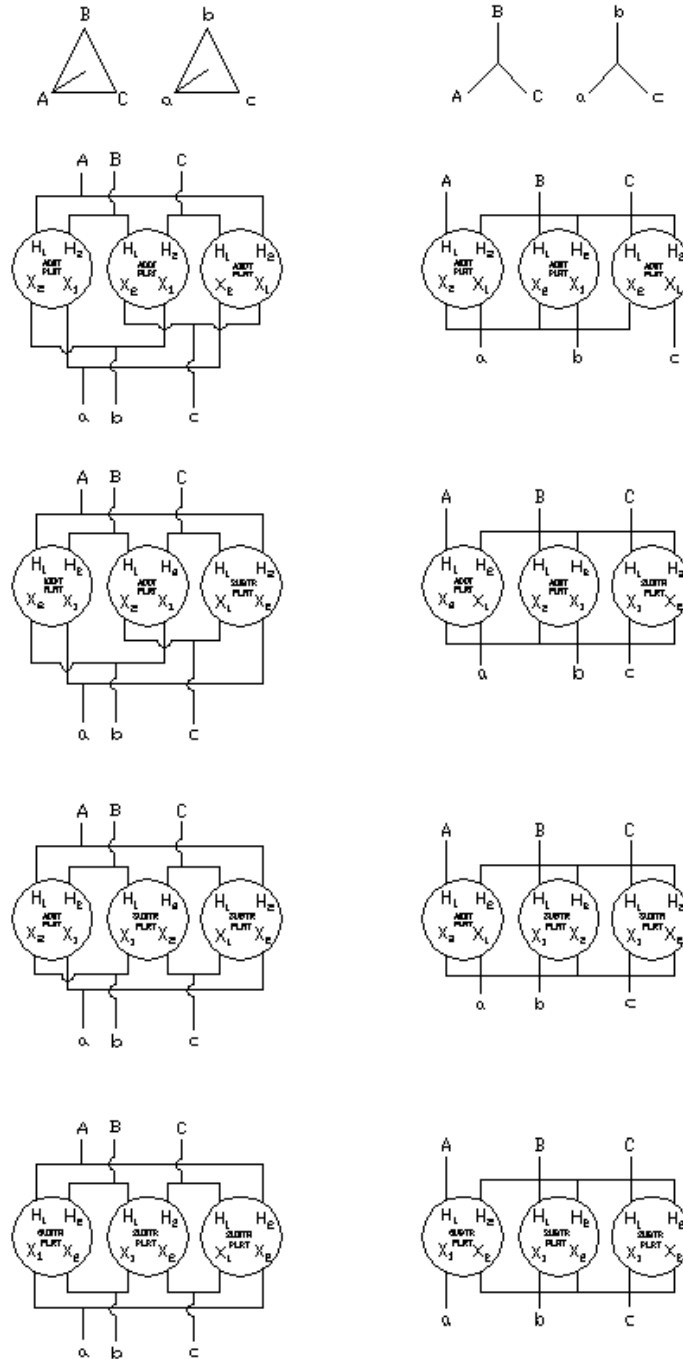

NOTE—This figure is included to illustrate connections of single-phase transformers of additive polarity, additive and subtractive polarity, and subtractive polarity in banks.

Figure 15—Single-phase transformers connected Δ-Δ and Y-Y in three-phase banks with 0° angular displacement

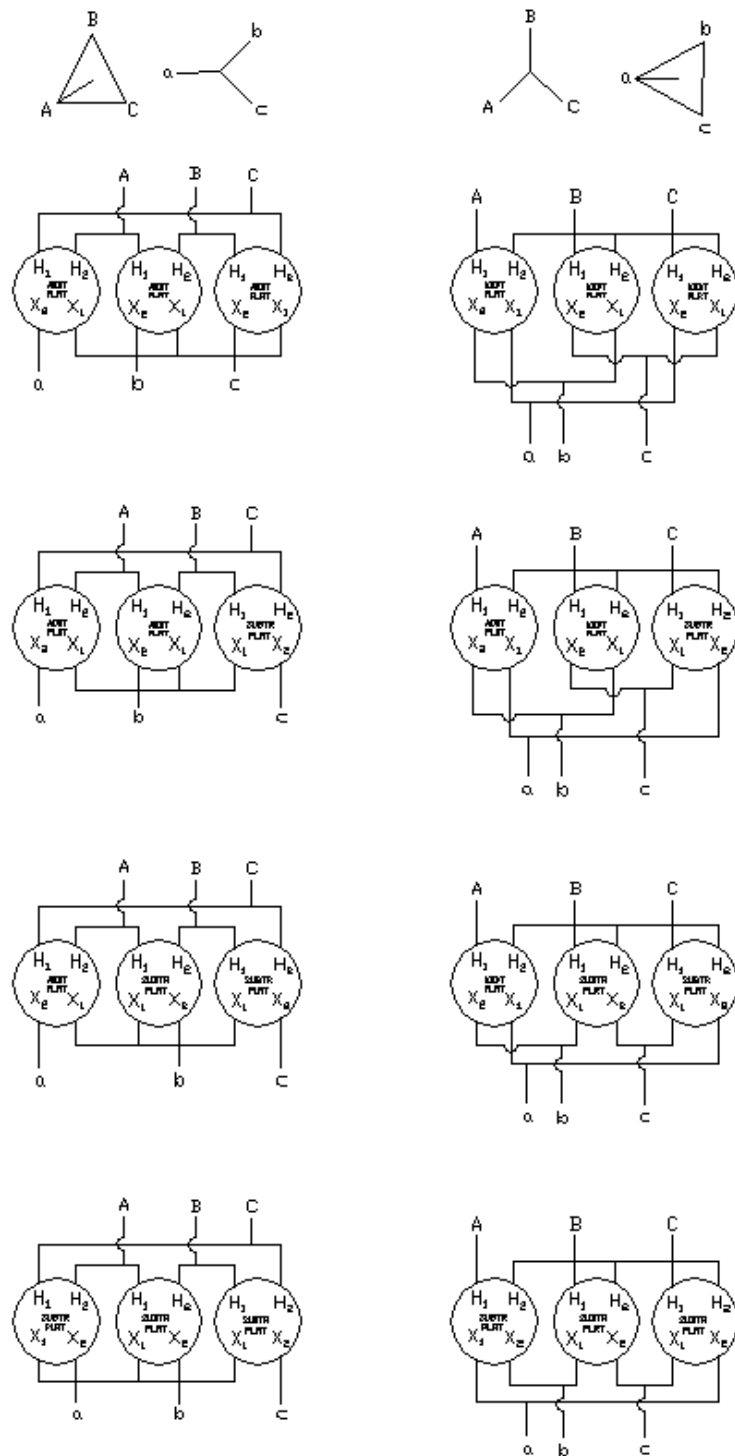

NOTE—This figure is included to illustrate connections of single-phase transformers of additive polarity, additive and subtractive polarity, and subtractive polarity in banks.

Figure 16—Single-phase transformers connected Δ -Y and Y- Δ in three-phase banks with 30° angular displacement

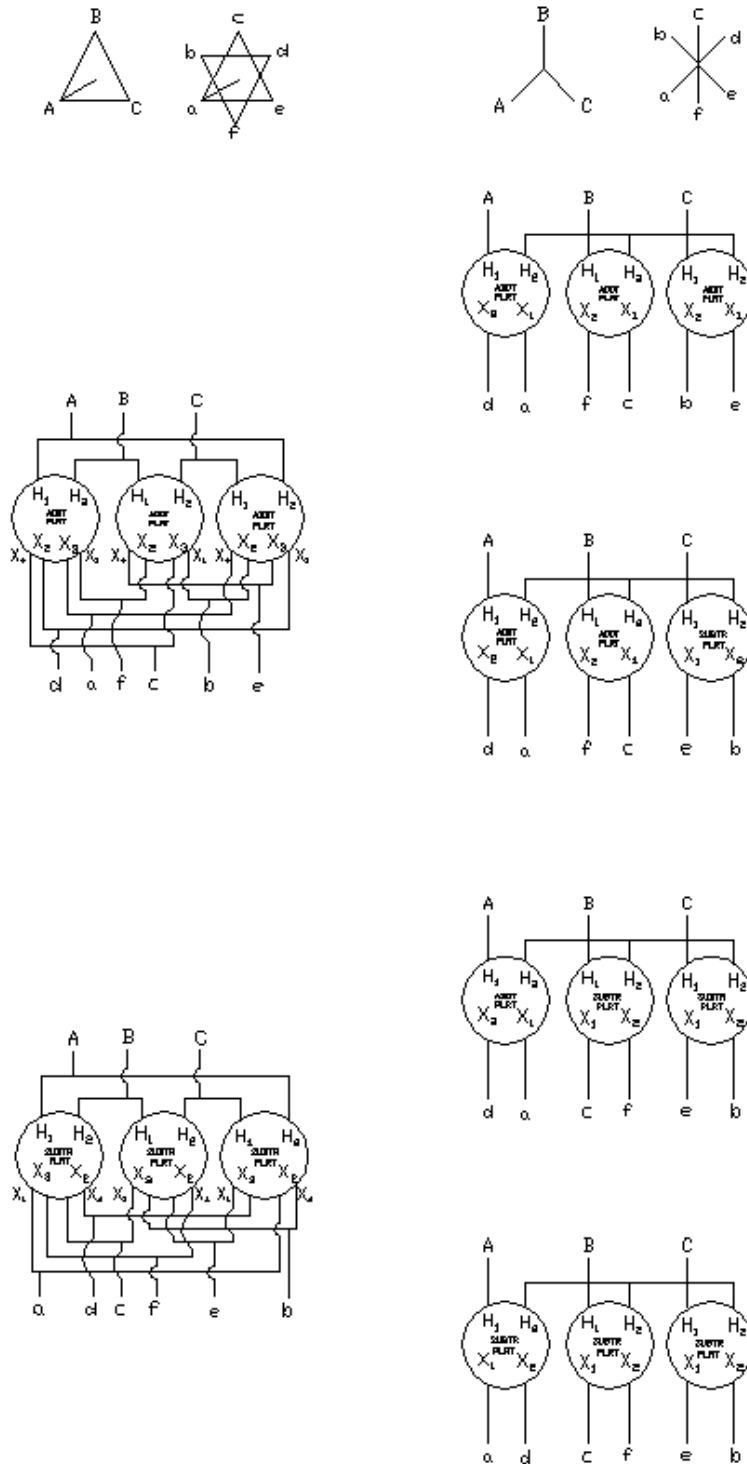

NOTE—This figure is included to illustrate connections of single-phase transformers of additive polarity, additive and subtractive polarity, and subtractive polarity in banks.

Figure 17—Single-phase transformers when transforming three- to six-phase with 0° angular displacement

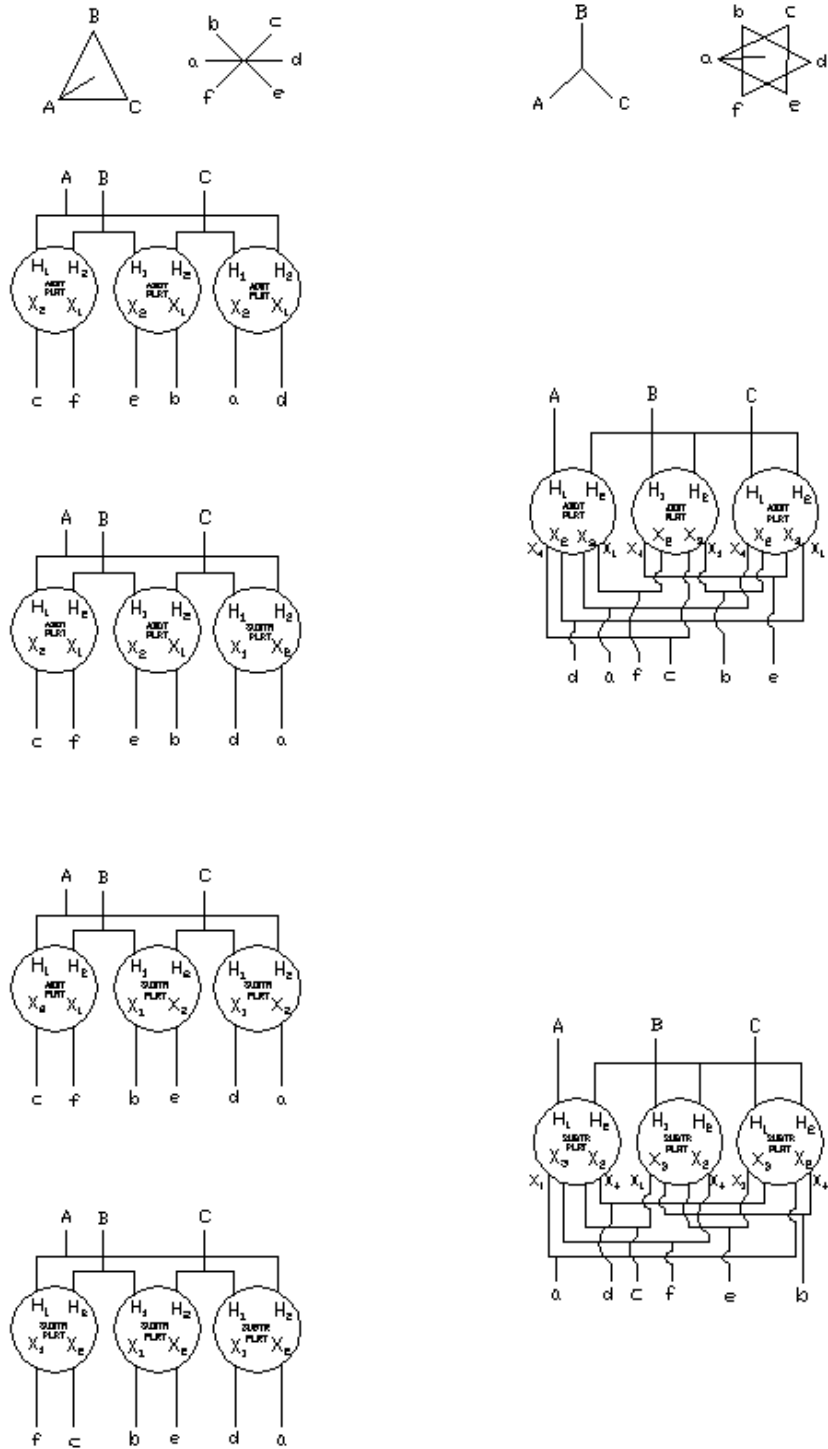

NOTE—This figure is included to illustrate connections of single-phase transformers of additive polarity, additive and subtractive polarity, and subtractive polarity in banks.

Figure 18—Single-phase transformers when transforming three- to six-phases with 30° angular displacement

5. Phase relationships and terminal markings for three-phase transformers

5.1 Relation between highest voltage winding and other windings

5.1.1 Phase sequence markings

The markings shall be so applied that if the phase sequence of voltage on the highest voltage winding is in the time order H_1, H_2, H_3 , it will be in the time order of X_1, X_2, X_3 , and Y_1, Y_2, Y_3 , etc., on the other windings.

5.1.2 Phase relationship markings

In order that the markings of terminals shall indicate definite phase relations, they shall be made in accordance with one of the three-phase groups shown in Figure 19. The angular displacement between the H winding and the X winding is the angle in each of the voltage phasor diagrams (see Figure 19), between the lines passing from its neutral point through H_1 and X_1 , respectively.

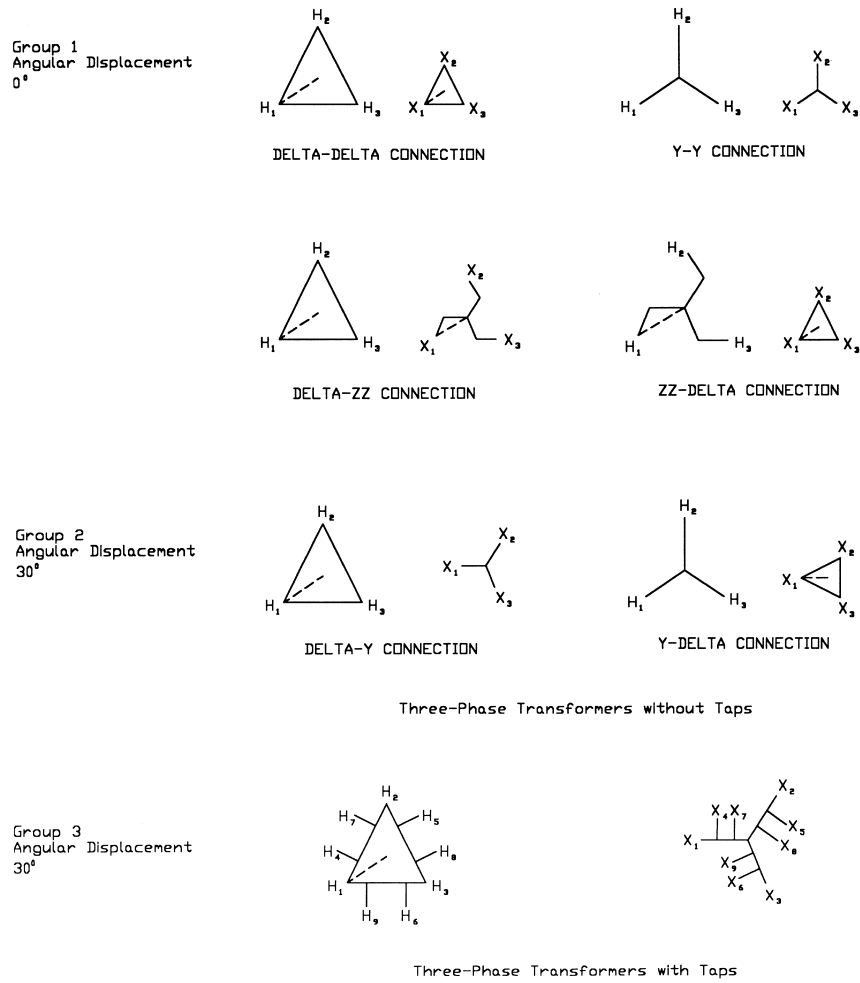

NOTES

- 1—This figure is included to illustrate the method of marking transformer terminals that are brought out of the case. Dash lines show angular displacement between high- and low-voltage windings.
- 2—Angular displacement is the angle between a line drawn from neutral to H_1 and a line drawn from neutral to X_1 , measured in a clockwise direction from H_1 to X_1 .
- 3—The zig-zag connections shown in Group 1 may also be achieved using the following internal connections.

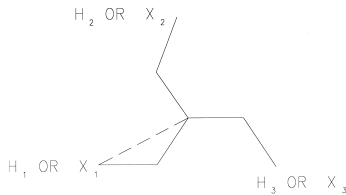

Figure 19—Terminal markings and voltage diagrams for three-phase transformer connections

5.2 Phase relationships and terminal markings

Phase relationships and terminal markings for liquid-insulated distribution transformers shall be as specified in general and product standards IEEE Std C57.12.00-2000, ANSI C57.12.20-1997, ANSI C57.12.22-1989, ANSI C57.12.24-1992, IEEE Std C57.12.26-1992, and ANSI C57.12.40-1994.

Phase relationships and terminal markings for liquid-insulated power transformers shall be as specified in general and product standards IEEE Std C57.12.00-2000 and ANSI C57.12.10-1988.

Phase relationships and terminal markings for dry-type distribution and power transformers shall be as specified in general and product standards IEEE Std C57.12.01-1998, ANSI C57.12.50-1981, ANSI C57.12.51-1981, and ANSI C57.12.52-1981.

5.3 Marking of full winding terminals

5.3.1 General

The three leads for each winding that connect to the full-phase windings of a three-phase transformer shall have their terminals marked H_1 , H_2 , H_3 , X_1 , X_2 , X_3 , Y_1 , Y_2 , Y_3 , etc., respectively.

5.3.2 Autotransformers

Three-phase autotransformer terminals shall be marked in accordance with the requirements for corresponding multiwinding transformers (see Figure 20, Group 3).

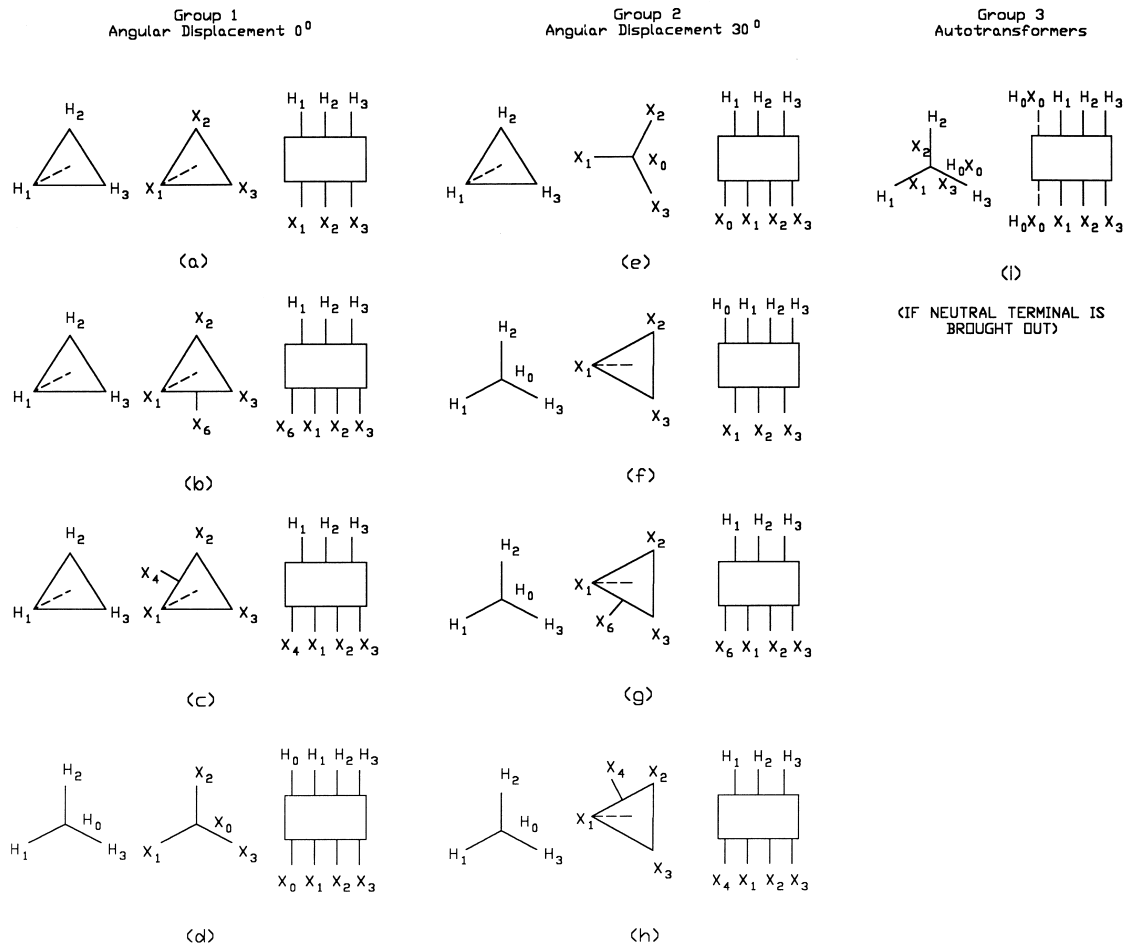

NOTES

- 1—Dash lines show angular displacement between high- and low-voltage windings.
- 2—Angular displacement is the angle between a line drawn from neutral to H_1 and a line drawn from neutral to X_1 measured in a clockwise direction from H_1 to X_1 .
- 3—(b), (c), (g), and (h) show mid tap brought out of one phase on the low-voltage side.

Figure 20—Angular displacement and terminal markings for three-phase transformers

5.4 Tap leads

In general, where tap leads are brought out of the case (neutral lead excepted) their terminals shall be marked with the proper letter followed by the subscripts 4, 7, etc., for one phase; 5, 8, etc., for a second phase; and 6, 9, etc., for the third phase (see Figure 19, Group 3).

For delta connections, the order of numbering tap terminals shall be as follows; 4, 7, etc., from terminal 1 toward terminal 2; 5, 8, etc., from terminal 2 toward terminal 3; and 6, 9, etc., from terminal 3 toward terminal 1 (see Figure 19, Group 3).

For wye connections, the order of numbering tap terminals shall be as follows; 4,7, etc., from terminal 1 toward neutral; 5, 8, etc., from terminal 2 toward neutral; and 6, 9, etc., from terminal 3 toward neutral (see Figure 19, Group 3).

For a delta-connected winding with a center-tap in one leg, two connections are in common use as described below

- a) Unless otherwise specified, a center-tap X_6 shall be provided in leg X_1X_3 , as shown in Figure 20(b) or Figure 20(g).

NOTE—This connection provides coordination with ANSI/NFPA 70-1996, paragraph 384-3(f), which requires that the B phase (commonly connected to X_2) shall have the higher voltage to ground.

- b) When specified, a center tap X_4 shall be provided in leg X_1X_2 , as shown in Figure 20(c) or Figure 20(h).

NOTE—This connection will also conform to ANSI/NFPA 70-1996, paragraph 384-3(f), if the B phase is connected to X_3 .

5.5 Location of external terminals

5.5.1 Station type transformers

For station type transformers, and others with high-voltage and low-voltage terminals on opposite sides of the case, the H_1 lead shall be brought to a terminal on the right-hand side of the case when facing the highest voltage side. The H_2 and H_3 terminals shall be arranged in numerical order reading from right to left when facing the highest voltage side. The H_0 terminal, if present, shall be located on the right of the H_1 terminal when facing the highest voltage side of the case (see Figure 20, Group 1 and Group 2).

The X_1 lead shall be brought to a terminal on the left-hand side of the case when facing the low-voltage side. The X_2 and X_3 terminals shall be arranged in numerical order, reading from left to right, when facing the X winding side of the case. The X_0 terminal, if present, shall be located to the left of the X_1 terminal when facing the X winding side of the case (see Figure 20, Group 1 and Group 2).

The Y winding and Z winding terminals, if present, shall be numbered in the same manner as the low-voltage terminals.

5.5.2 Secondary network, subway, and vault-type transformers

Locations of line and neutral terminals of secondary network, subway, and vault-type transformers differs from the locations above and are shown in ANSI C57.12.40-1994.

5.5.3 Unit substation transformers

The winding terminals of “standard” and “reverse” unit substation transformers shall be located in accordance with Figure 21 or Figure 22.

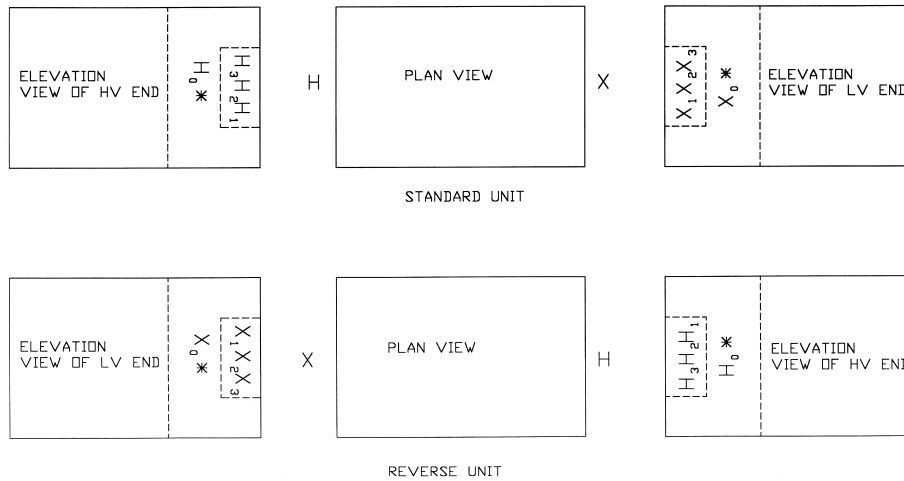

NOTE—High-voltage terminals are denoted by H and low-voltage terminals are denoted by X.

*Neutral shall be located within dotted zone.

Figure 21—Terminal markings and locations for unit substation transformers with high- and low-voltage sidewall bushings

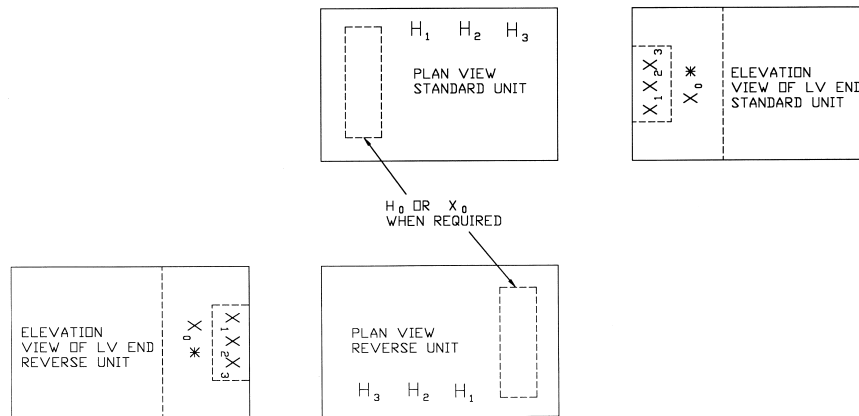

*Neutral shall be located within dotted zone.

Figure 22—Terminal markings and locations for unit substation transformers with high-voltage cover bushings

When specified, winding terminals of “standard” and “reverse,” or “right” and “left”-hand units, may have other terminal markings or arrangements.

5.5.4 Padmounted, compartmental-type transformers

For padmounted compartmental-type transformers with all terminals on one side of the case, the high-voltage compartment shall be located on the left side of the case, when facing the terminal side of the case. The H_1 terminal shall be located on the left of the high-voltage compartment. The compartment with the low-voltage terminals shall be grouped on the right-hand side of the case when facing the terminal side of the

case. The low-voltage neutral terminal, when required, shall be located to the left side of the low-voltage terminal grouping followed by X_1 , X_2 , and X_3 in a left-to-right-arrangement. ANSI C57.12.22-1989 and IEEE Std C57.12.26-1992 should be referred to for the arrangements and specific dimensional requirements of the terminal arrangements.

5.6 Interphase connections made outside of case

Where the interphase connections are made outside the case, the terminals shall be marked with the proper letter followed by the numbers 1, 4, 7, 10, etc., for one phase; 2, 5, 8, 11, etc., for the second phase; and 3, 6, 9, 12, etc., for the third phase.

The markings shall be so applied that when a wye connection is made by joining together the highest numbered terminals of each phase, the requirements in this standard will apply except for 2.4.

5.7 Parallel operation

Transformers having terminals marked in accordance with this standard may be operated in parallel by connecting similarly marked terminals together, provided that their angular displacements are the same and also provided that their ratios, voltages, resistances, reactances, and ground connections are such as to permit parallel operation.

NOTE—In some cases, designs may be such as to permit parallel operation, although owing to a difference in the number of tap terminals, the terminals to be connected together may not be similarly marked.

6. Terminal markings for three-phase to six-phase transformers

6.1 General

The requirements for three-phase to six-phase transformers are set up on the basis that the three-phase winding is always the H winding.

6.2 Marking of full winding terminals

The three terminals that connect to the three-phase winding shall be marked H_1 , H_2 , H_3 , and the six terminals that connect to the full six-phase winding shall be marked X_1 , X_2 , X_3 , X_4 , X_5 , X_6 (see Figure 23, Group 1 and Group 2).

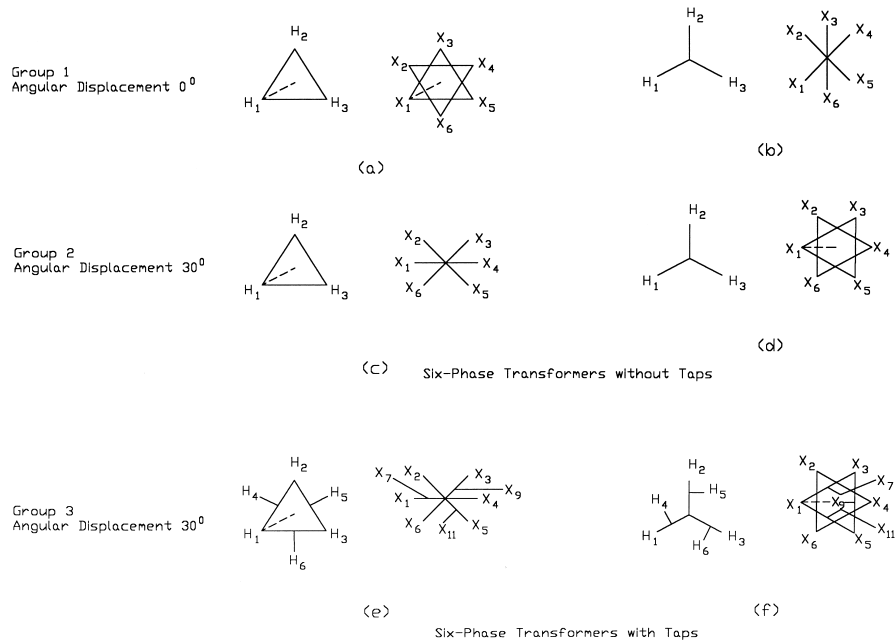

NOTES

- 1—This figure is included to illustrate the method of marking transformer terminals that are brought out of the case. Dash lines show angular displacement between high- and low-voltage windings.
- 2—Angular displacement is the angle between a line drawn from neutral to H_1 and a line drawn from neutral to X_1 measured in a clockwise direction from H_1 to X_1 .

Figure 23—Terminal markings and voltage phasor diagrams for usual six-phase transformer connections

6.3 Relation between three-phase and six-phase windings

The markings shall be so applied that if the phase sequence of voltage on the three-phase terminals is in the order H_1, H_2, H_3 , it is in the time order $X_1, X_2, X_3, X_4, X_5, X_6$ on the six-phase terminals.

In order that the markings of terminal connections between phases will indicate definite phase relations, they shall be made in accordance with one of the four six-phase groups shown in Figure 23, Group 1 and Group 2. The angular displacement between the three-phase and six-phase windings is the angle in each of the voltage phasor diagrams from its neutral through H_1 and X_1 , respectively.

6.4 Tap leads

Where tap leads from the six-phase windings are brought out of the case (neutral lead excepted), they shall have terminals marked as designated in 6.4.1 and 6.4.2.

6.4.1 Diametrical connections

Tap terminals shall be marked from the two ends of each phase winding toward the middle or neutral point in the following order:

- a) X_7, X_{13} , etc., from X_1 toward neutral
- b) X_8, X_{14} , etc., from X_2 toward neutral

- c) X_9, X_{15} , etc., from X_3 toward neutral
- d) X_{10}, X_{16} , etc., from X_4 toward neutral
- e) X_{11}, X_{17} , etc., from X_5 toward neutral
- f) X_{12}, X_{18} , etc., from X_6 toward neutral

See Figure 23(e).

A tap from the middle point of any phase winding not intended as a neutral shall be given a number determined by counting from X_1, X_2 , or X_3 and not from X_4, X_5 , or X_6 . For example, if the only taps brought out are 50% starting taps, they shall be numbered X_7, X_9 , and X_{11} .

6.4.2 Double-delta connection

Tap terminals shall be marked in the following order:

- a) X_7, X_{13} , etc., from X_1 toward X_3
- b) X_8, X_{14} , etc., from X_2 toward X_4
- c) X_9, X_{15} , etc., from X_3 toward X_5
- d) X_{10}, X_{16} , etc., from X_4 toward X_6
- e) X_{11}, X_{17} , etc., from X_5 toward X_1
- f) X_{12}, X_{18} , etc., from X_6 toward X_2

See Figure 23(f).

7. Use of transformers with standard voltage diagrams in connecting systems of various phase displacements

7.1 General

On the basis of two power or source systems (hereafter referred to as systems), one with phase terminals arbitrarily designated by A, B, C, and the other by a, b, c, the phase displacement of “a” with respect to “A” may be from 0° to 330° in steps of 30° . Examples are given in 7.2 through 7.4 of transformer connections that may be made to transformers for any of these displacements.

7.2 0° phase displacement: Δ-Δ or Y-Y

The following examples are for Δ-Δ connections with system displacements of 0°, 120°, and 240°.

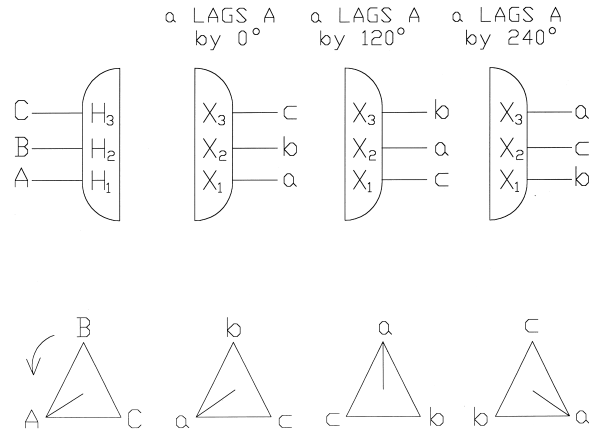

7.3 30° lagging phase displacement: Δ-Y or Y-Δ

The following examples are for Δ-Y connections with system displacements of 30°, 150°, and 270° lagging.

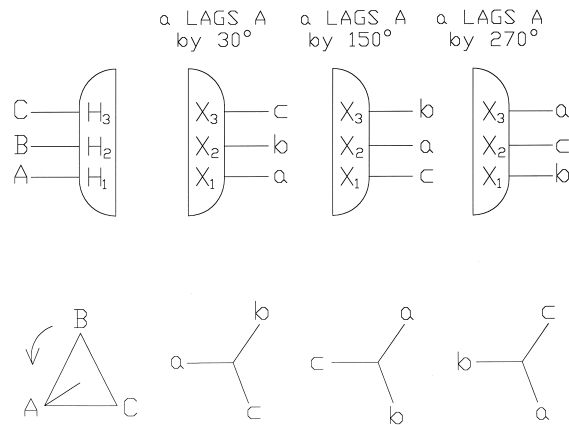

7.4 30° leading phase displacement: Δ-Y or Y-Δ

To connect systems with 30°, 270°, or 150° leading displacements, the procedure given in 7.3 is followed, except that the sequence of connecting system terminals to the transformer is reversed by reversing any pair of terminals on both systems, such as B, C and b, c.

For example, again using the Δ-Y diagram, when the diagram is shown in the usual form, the change in the sequence of connections results in a reversal of phase rotation as seen by the transformer terminals. Expressed in the recognized counterclockwise rotation, the equivalent diagrams are as follows.

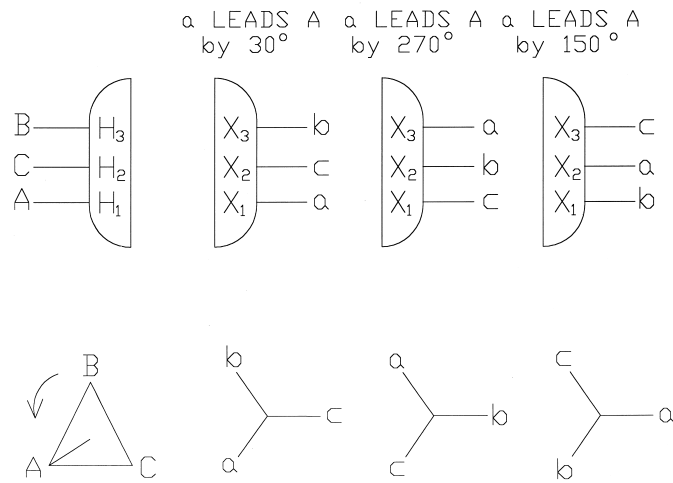

The leading displacements mentioned above can be expressed as lagging displacements for reference consistency by subtracting the lead angle degrees from 360° . For example, the 30° leading displacement is the same as 330° lagging displacement.

7.5 Summary of preceding examples

System	Displacement	Degrees	See section	Lag/lead
0	120	240	7.2	Lagging
30	150	270	7.3	Lagging
30	270	150	7.4	Leading